

IORI DM200APE



**35M Rope
Now
Available!**

Technical Data

Rated capacity	200kg	Number of strands	133N
Mass of hoist	24kg	Diameter of strand	0.27mm
Lifting speed	20 M/min	Declared breaking load	11.7kn
Electric motor	Monofase	Unit resistant	1960N/mm ²
Power	0.75kw	Length of rope	25m
Voltage	110v	Dimensions	
Frequency	50Hz	Length	370mm
Shaft rotation speed	1400 giri/min	Width	320mm
Reduction ratio	1:25.9	Height	280mm
Rotation – resistant steel	4mm		

Product Code	Description	Weight kg
IO001101	DM200APE Hoist 110V + B3 Ext. Bracket	34



Tel: 01827 282000 Fax: 01827 289991
sales@haki.co.uk

IORI DM200APE



IO000095

Window Pole

360 Degree Bracket



IO001011

Scaffold Fixing Frame

180 Degree

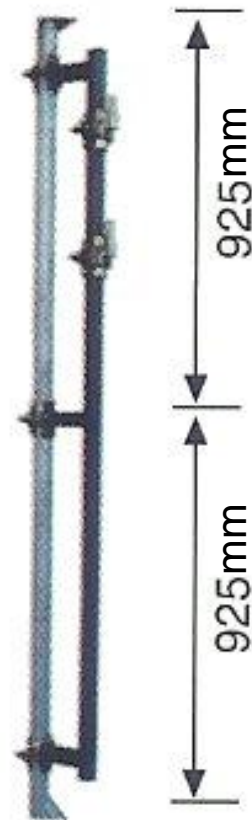

Product Code	Description	Weight kg
IO001011	Scaffold Fixing Frame - 180	16
IO000095	Window Pole 360 Bracket	39



Tel: 01827 282000 Fax: 01827 289991
sales@haki.co.uk

IORI DM200APE

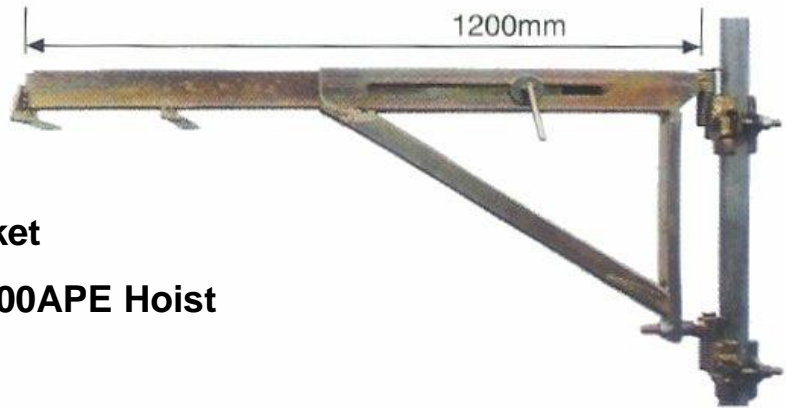

B3 Extendable Bracket
 – included with DM200APE Hoist

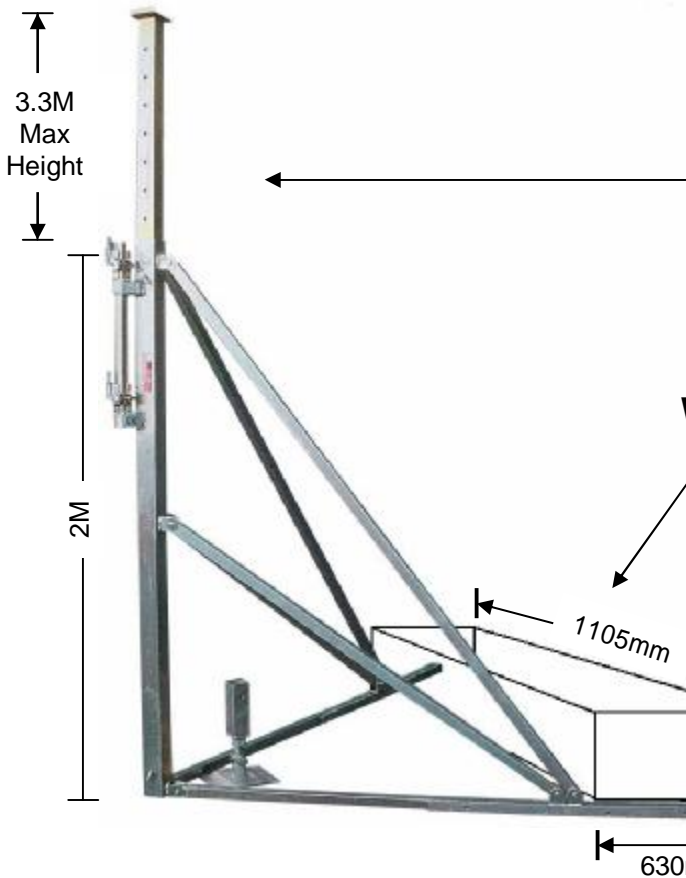

IO001003
Window Bracket Set

IO001013
Weight Box for Window Bracket Set (ballast not included)

These items must be used together.

Product Code	Description	Weight kg
IO001003	Window Bracket Set	80
IO001013	Weight Box for Window Bracket Set	50



Tel: 01827 282000 Fax: 01827 289991
sales@haki.co.uk