

Excavator hook VCGH-G for bolting

Safety instructions

This safety instruction / declaration of the manufacturer has to be kept on file for the whole lifetime of the product.



RUD Ketten
Rieger & Dietz GmbH u. Co. KG
 D-73428 Aalen / Germany
 Tel. +49 (0)7361/504-1371 /
 1314/1527
 Fax +49 (0)7361/504-1460
 www.rud.com
 info@rud.com

RUD-Art.-Nr.: 8502511-EN / 07.006

Excavator hook
VCGH-G
for bolting

EG-Herstellererklärung

im Sinne der EG-Maschinenrichtlinie 98/37/EG,
Anhang II B und ihre Änderungen

Hiermit erklären wir (unterstützt durch die Zertifizierung nach ISO 9001), daß die nachfolgend bezeichnete Ausrüstung aufgrund ihrer Konzipierung und Bauart, sowie der von uns in Verkehr gebrachten Ausführung, den einschlägigen grundlegenden Sicherheits- und Gesundheitsanforderungen der EG-Richtlinie entspricht. Bei einer nicht mit uns abgestimmten Änderung der Ausrüstung verliert diese Erklärung ihre Gültigkeit. Weiterhin verliert diese Erklärung ihre Gültigkeit, wenn die Ausrüstung nicht entsprechend den in der Betriebsanleitung aufgezeigten bestimmungsmäßigen Fällen eingesetzt wird und die regelmäßig durchzuführenden Überprüfungen laut BGR 500, Kapitel 2.8 „Betreiben von Lastaufnahmeeinrichtungen im Hebezeugbetrieb“, und den entsprechenden landesspezifischen Vorschriften, nicht vorgenommen werden.

Hinweis: Die Inbetriebnahme der Maschine, an die die gelieferten Bauteile angebaut werden, ist solange untersagt, bis festgestellt wurde, daß sie den Bestimmungen der Maschinenrichtlinie 98/37/EG der Europäischen Gemeinschaft entspricht. Beim Anbauhaken angewendete harmonisierte Normen DIN EN ISO 12100 T1 und T2 sowie in Anlehnung an EN 1677. Dies gilt nur für Mitgliedstaaten der EU und EFTA.

Bezeichnung der Ausrüstung:

Anschlagpunkt

Type: **Anbauhaken schraubbar - VCGH-G**

Herstellerzeichen: 

EC-Declaration of the manufacturer

according to the Machinery Directive 98/37/EC,
annex II B and amendments

We hereby declare (supported by certification as per ISO 9001) that the equipment, as mentioned below, corresponds to the appropriate, basic requirements of safety and health of the corresponding EC regulation in the design as it is sold by us because of its design and construction. In case of any modification of the equipment, not being agreed upon with us, this declaration becomes invalid. Furthermore, this declaration will become invalid if the equipment is not used according to the prescriptions mentioned in the manual and if the necessary examinations are not carried out regularly as per BGR 500.

Hint: The commissioning of the machine in which the delivered components of this consignment will be installed is only permitted if it can be stated that the machine corresponds to the machine directive 98/37/EC of the European Community. Applied standards: DIN EN ISO 12100 T1 and T2 in particular EN 1677. This is only valid for countries which are member of the EC and of the EFTA.

Designation of the equipment:

Lifting point

Type: **Excavator hook for bolting - VCGH-G**

Manufacturer's sign: 

User Instructions

- Reference should be made to German Standards accord. BGR 500 or other country specific statutory regulations and inspections are to be carried out by competent persons only.
- Before installing and every use, visually inspect RUD lifting points, paying particular attention to any evidence of corrosion, wear and weld cracks and deformations. Please ensure compatibility of bolt thread and tapped hole.
- The material construction to which the lifting point will be attached should be of adequate strength to withstand forces during lifting without deformation. The German testing authority BG, recommends the following minimum bolt lengths:
 - 1 x M in steel (minimum quality S235JR [1.0037])
 - 1,25 x M in cast iron (for example GG 25)
 - 2 x M in aluminium alloys
 - 2,5 x M in aluminium-magnesium alloys
 (M = diameter of RUD lifting point bolt, for ex. M 20)

When lifting light metals, nonferrous heavy metals and gray cast iron the thread has to be chosen in such a way that the working load limit of the thread corresponds to the requirements of the respective base material.

RUD excavator hooks are delivered with 100 % crack tested bolts. **When using your own bolts, the bolts have to be 100% crack tested.** The min quality of the hexagon bolt had to be 10.9 accord. EN 24014 (DIN 931) with the nominal diameter.

- The lifting points must be positioned on the load in such a way that movement is avoided during lifting.
 - For single leg lifts, the lifting point should be vertically above the centre of gravity of the load.
 - For two leg lifts, the lifting points must be equidistant to/or above the centre of gravity of the load.
 - For three and four leg lifts, the lifting points should be arranged symmetrically around the centre of gravity in the same plane, if possible.

5. Load Symmetry:

The working load limit of individual RUD lifting points are calculated using the following formula and are based on symmetrical loading:

$$W_{LL} = \frac{G}{n \times \cos \beta}$$

W_{LL} = working load limit
 G = load weight (kg)
 n = number of load bearing legs
 β = angle of inclination of the chain to the vertical

The calculation of load bearing legs is as follows:

| | symmetrical | asymmetrical |
|------------------|-------------|--------------|
| two leg | 2 | 1 |
| three / four leg | 3 | 2 |

(see table 1)

6. A Plane bolting surface must be guaranteed. The holes must be drilled with a sufficient depth in order to guarantee compatibility with the supporting surface. *The bolts should be tightened with torque according to table 2.*

7. The installation should be in the direction of pull.

Possible use area:

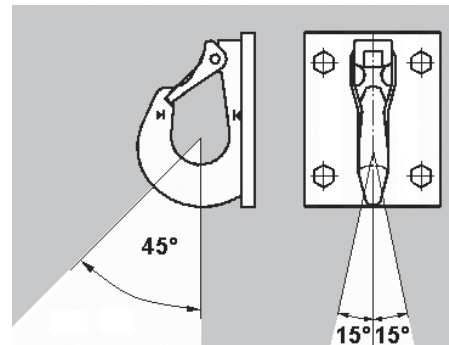

- To prevent unintended dismounting through shock loading, rotation or vibration, thread locking fluid such as Loctite (depending on the application, please pay attention to the manufacturer's instruction) could be used to secure the bolt, or use form-closed devices.
- All fittings connected to the VCGH-G should be free moving. When connecting and disconnecting the lifting means (sling chain) pinches and impacts should be avoided. Damage of the lifting means caused by sharp edges should be avoided as well.

A non-adherence to this advice may result damages of persons and materials !

| Method of lift | | | | | | | | | |
|---|-----------------------------------|-------|-------|--------|---------|---------|---------|---------|-------|
| Number of legs | 1 | 2 | 2 | 2 | 2 | 3 and 4 | 3 and 4 | 3 and 4 | |
| Angle of inclination β | 90° | 90° | 0-45° | 45-60° | unsymm. | 0-45° | 45-60° | unsymm. | |
| Factor | 1 | 2 | 1,4 | 1 | 1 | 2,1 | 1,5 | 1 | |
| Type | WLL in metric tons, bolted | | | | | | | | |
| | VCGH-G 6 * | 1,5 t | 3 t | 2,1 t | 1,5 t | 1,5 t | 3,15 t | 2,25 t | 1,5 t |
| | VCGH-G 8 * | 2,5 t | 5 t | 3,5 t | 2,5 t | 2,5 t | 5,25 t | 3,75 t | 2,5 t |
| | VCGH-G 10 * | 4 t | 8 t | 5,6 t | 4 t | 4 t | 8,4 t | 6 t | 4 t |
| | VCGH-G 13 * | 6,5 t | 13 t | 9,1 t | 6,5 t | 6,5 t | 13,65 t | 9,75 t | 6,5 t |
| | VCGH-G 16 | 10 t | 20 t | 14 t | 10 t | 10 t | 21 t | 15 t | 10 t |
| | VCGH-G 20 | 16 t | 32 t | 22,4 t | 16 t | 16 t | 33,6 t | 24 t | 16 t |
| | VCGH-G 22 | 20 t | 40 t | 28 t | 20 t | 20 t | 42 t | 30 t | 20 t |

Table 1

* are replaced by Type VABH-B

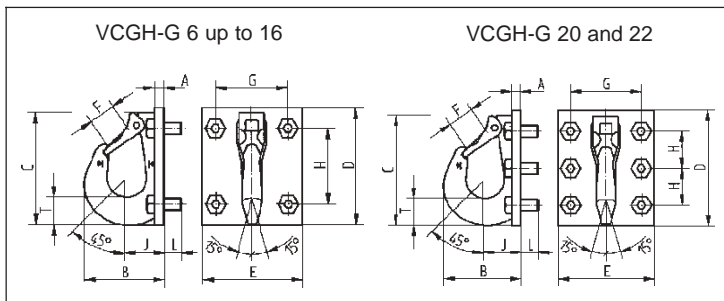

| Type | WLL t | weight kg | A | B | C | D | E | F | G | H | J | L | M | T | torque Nm | ref-no. | safety latch |
|-------------|----------|--------------|----|-----|-----|-----|-----|----|-----|-----|----|----|-------|----|--------------|-----------------|--------------|
| VCGH-G 6 * | 1,5 | 0,9 | 10 | 68 | 92 | 100 | 100 | 25 | 70 | 60 | 37 | 15 | 4xM12 | 20 | 100 | 7984040* | 7100299 |
| VCGH-G 8 * | 2,5 | 1,7 | 10 | 84 | 125 | 135 | 110 | 30 | 80 | 75 | 41 | 15 | 4xM12 | 28 | 100 | 7984042* | 7100300 |
| VCGH-G 10 * | 4 | 2,4 | 12 | 106 | 148 | 155 | 130 | 35 | 95 | 100 | 50 | 23 | 4xM16 | 36 | 240 | 7984044* | 7100301 |
| VCGH-G 13 * | 6,5 | 4,4 | 15 | 120 | 170 | 185 | 160 | 40 | 110 | 120 | 60 | 25 | 4xM20 | 38 | 450 | 7984046* | 7100302 |
| VCGH-G 16 | 10 | 6,4 | 15 | 141 | 200 | 220 | 170 | 48 | 120 | 150 | 70 | 35 | 4xM24 | 50 | 800 | 7984048 | 7100303 |
| VCGH-G 20 | 16 | 10,4 | 20 | 187 | 272 | 288 | 210 | 63 | 150 | 110 | 87 | 30 | 6xM24 | 70 | 800 | 7984311 | 7101604 |
| VCGH-G 22 | 20 | 17,5 | 20 | 196 | 276 | 292 | 240 | 63 | 150 | 110 | 92 | 30 | 6xM24 | 75 | 950 | 7984312 | 7101604 |

Table 2

* are replaced by Type VABH-B

10. Effects of temperature:

Due to the DIN/EN bolts that are used with the VCGH-G the working load limit should be reduced accordingly:

| | | |
|---------------|--------------|----------------|
| -20° to 100°C | no reduktion | -4°F to 212°F |
| 100° to 200°C | minus 15% | 212°F to 392°F |
| 200° to 250°C | minus 20% | 392°F to 482°F |
| 250° to 350°C | minus 25% | 482°F to 662°F |

Temperatures above 350°C (662°F) are not permitted.

11. RUD-Lifting points must not be used under chemical influences such as acids, alkaline solutions and vapours e.g. in pickling baths or hot dip galvanising plants. If this cannot be avoided, please contact the manufacturer indicating the concentration, period of penetration and temperature of use.

12. The places where the lifting points are fixed should be marked with colour.

13. After fitting, an annual inspection or sooner if conditions dicate should be undertaken by a competent person examining the continued suitability. Also after damage and special occurrences.

Inspection criteria concerning paragraphs 2 and 13:

- Ensure correct bolt and nut size, quality and length.
- Ensure compatibility of bolt thread and tapped hole - control of the torque
- The lifting point should be complete.
- The excavator hook has to be mount on plane bolting surfaces with the full side.
- The working load limit and manufacturers stamp should be clearly visible.
- Deformation of the component parts such as body and bolt.
- Mechanical damage, such as notches, particularly in high stress areas.
- Wear should be no more than 10%
- opening of the mouth is deformed more than 10%
- Evidence of corrosion.
- Evidence of cracks.

| Method of lift | | | | | | | | |
|--|---------------------------|-------|-------|--------|---------|---------|---------|---------|
| Number of legs | 1 | 2 | 2 | 2 | 2 | 3 and 4 | 3 and 4 | 3 and 4 |
| Angle of inclination α | 90° | 90° | 0-45° | 45-60° | unsymm. | 0-45° | 45-60° | unsymm. |
| Factor | 1 | 2 | 1,4 | 1 | 1 | 2,1 | 1,5 | 1 |
| Type | WLL in lbs, bolted | | | | | | | |
| VCGH-G 6 * | 3300 | 6600 | 4620 | 3300 | 3300 | 6930 | 4950 | 3300 |
| VCGH-G 8 * | 5500 | 11000 | 7700 | 5500 | 5500 | 11550 | 8250 | 5500 |
| VCGH-G 10 * | 8800 | 17600 | 12300 | 8800 | 8800 | 18500 | 13200 | 8800 |
| VCGH-G 13 * | 14300 | 28600 | 20000 | 14300 | 14300 | 30000 | 21450 | 14300 |
| VCGH-G 16 | 22000 | 44000 | 30800 | 22000 | 22000 | 46200 | 33000 | 22000 |
| VCGH-G 20 | 35200 | 70400 | 49300 | 35200 | 35200 | 74000 | 52800 | 35200 |
| VCGH-G 22 | 44000 | 88000 | 61600 | 44000 | 44000 | 92400 | 66000 | 44000 |

Table 3

* are replaced by Type VABH-B