

Excavator hook - for welding - VCGH-S



Safety instructions

This safety instruction / declaration of the manufacturer has to be kept on file for the whole lifetime of the product.

Excavator hook - for welding VCGH-S



RUD Ketten
Rieger & Dietz GmbH u. Co. KG
D-73428 Aalen / Germany
Tel. +49 (0)7361/504-1371 /
1314/1527
Fax +49 (0)7361/504-1460
www.rud.com
info@rud.com

RUD-Art.-Nr.: 8502510-EN / 07.006

EG-Herstellererklärung

im Sinne der EG-Maschinenrichtlinie 98/37/EG,
Anhang II B und ihre Änderungen

Hiermit erklären wir (unterstützt durch die Zertifizierung nach ISO 9001), daß die nachfolgend bezeichnete Ausrüstung aufgrund ihrer Konzipierung und Bauart, sowie der von uns in Verkehr gebrachten Ausführung, den einschlägigen grundlegenden Sicherheits- und Gesundheitsanforderungen der EG-Richtlinie entspricht. Bei einer nicht mit uns abgestimmten Änderung der Ausrüstung verliert diese Erklärung ihre Gültigkeit. Weiterhin verliert diese Erklärung ihre Gültigkeit, wenn die Ausrüstung nicht entsprechend den in der Betriebsanleitung aufgezeigten bestimmungsmäßigen Fällen eingesetzt wird und die regelmäßig durchzuführenden Überprüfungen laut BGR 500, Kapitel 2.8 „Betreiben von Lastaufnahmeeinrichtungen im Hebezeugbetrieb“, und den entsprechenden landesspezifische Vorschriften, nicht vorgenommen werden.

Hinweis: Die Inbetriebnahme der Maschine, an die die gelieferten Bauteile angebaut werden, ist solange untersagt, bis festgestellt wurde, daß sie den Bestimmungen der Maschinenrichtlinie 98/37/EG der Europäischen Gemeinschaft entspricht. Beim Anbauhaken angewendete harmonisierte Normen DIN EN ISO 12100 T1 und T2 sowie in Anlehnung an EN 1677. Dies gilt nur für Mitgliedstaaten der EU und EFTA.

Bezeichnung der Ausrüstung:

Anschlagpunkt

Type: **Anbauhaken schweißbar - VCGH-S**

Herstellerzeichen: 

EC-Declaration of the manufacturer

according to the Machinery Directive 98/37/EC,
annex II B and amendments

We hereby declare (supported by certification as per ISO 9001) that the equipment, as mentioned below, corresponds to the appropriate, basic requirements of safety and health of the corresponding EC regulation in the design as it is sold by us because of its design and construction. In case of any modification of the equipment, not being agreed upon with us, this declaration becomes invalid. Furthermore, this declaration will become invalid if the equipment is not used according to the prescriptions mentioned in the manual and if the necessary examinations are not carried out regularly as per BGR 500.

Hint: The commissioning of the machine in which the delivered components of this consignment will be installed is only permitted if it can be stated that the machine corresponds to the machine directive 98/37/EC of the European Community. Applied standards: DIN EN ISO 12100 T1 and T2 in particular EN 1677. This is only valid for countries which are member of the EC and of the EFTA.

Designation of the equipment:

Lifting point

Type: **Excavator hook - for welding - VCGH-S**

Manufacturer's sign: 

User Instructions

- Reference should be made to German Standards according BGR 500 or other country specific statutory regulations and inspections are to be carried out by competent persons only.
- Before installing and every use, visually inspect RUD lifting points, paying particular attention to any evidence of weld cracks, corrosion, wear, deformations, etc.
- The material construction to which the lifting point will be attached should be of adequate strength to withstand forces during lifting without deformation. The contact areas must be free from impurities, oil, colour, ect.

The Material of the welding plate is S355J2G3 (1.0577+N (St52-3)).

- The lifting points must be positioned on the load in such a way that movement is avoided during lifting.
 - For single leg lifts, the lifting point should be vertically above the centre of gravity of the load.
 - For two leg lifts, the lifting points must be equidistant to/or above the centre of gravity of the load.
 - For three and four leg lifts, the lifting points should be arranged symmetrically around the centre of gravity in the same plane.

5. Load Symmetry:

The working load limits of individual RUD lifting points are calculated using the following formula and are based on symmetrical loading:

$$W_{LL} = \frac{G}{n \times \cos \beta}$$

W_{LL} = working load limit
 G = load weight (kg)
 n = number of load bearing legs
 β = angle of inclination of the chain to the vertical

The calculation of load bearing legs is as follows:

	symmetrical	asymmetrical
two leg	2	1
three / four leg	3	2

(see table 1)

- The installation should be in the direction of pull.

Possible use area:

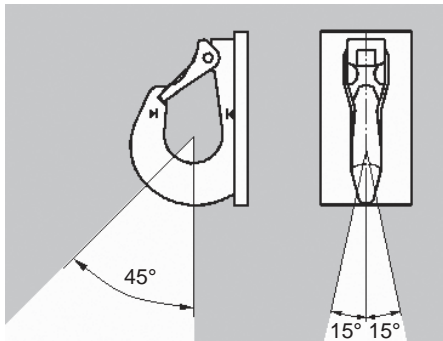

- All fittings connected to the VCGH-S should be free moving. When connecting and disconnecting the lifting means (sling chain), pinches and impacts should be avoided. Damage of the lifting means caused by sharp edges should be avoided as well.

8. Effect of temperatur:

During use in overheated areas the WLL of the VCGH-S has to be reduced according the chart:

-40° up to 200°C	no reduction
200° up to 300°C	minus 10% (392°F up to 572°F)
300° up to 400°C	minus 25% (572°F up to 752°F)

Temperatures above 400°C (752°F) are not allowed.

- The places where the lifting points are fixed should be marked with colour.

- RUD-Lifting points must not be used under chemical influences such as acids, alkaline solutions and vapours e.g. in pickling baths or hot dip galvanising plants. If this cannot avoided, please contact the manufacturer indicating the concentration, period of penetration and temperature of use.

- If the lifting points are used **exclusively** for lashing the value of the working load limit can be doubled.

$$LC = 2 \times WLL$$

- After welding, an annual inspection or sooner if conditions dicate should be undertaken by a competent person examining the continued suitability. Also after damage and special occurrences.

Inspection criteria concerning paragraphs 2 and 12:

- The lifting point should be complete.
- The working load limit and manufacturers stamp should be clearly visible.
- Deformation of the component parts such as body .
- Mechanical damage, such as notches, particularly in high stress areas.
- Wear should be no more than 10% of cross sectional diameter.
- Evidence of corrosion.
- Evidence of cracks.
- Cracks or other damages to the welding.

A non-adherence to this advice may result damages of persons and materials!

Method of lift													
Number of legs	1		2		2	2	2	3 and 4	3 and 4	3 and 4		3 and 4	
Angle of inclination β	90°		90°		0-45°	45-60°	unsymm.	0-45°	45-60°	unsymm.		unsymm.	
Factor	1		2		1,4	1	1	2,1	1,5	1		1	
type	WLL (total weight) in tonnes												
VCGH-S 6 *	1,5 t 3300 lbs	3 t 6600 lbs	2,1 t 4620 lbs	1,5 t 3300 lbs	1,5 t 3300 lbs	3,15 t 6930 lbs	2,25 t 4950 lbs	1,5 t 3300 lbs					
VCGH-S 8 *	2,5 t 5500 lbs	5 t 11000 lbs	3,5 t 7700 lbs	2,5 t 5500 lbs	2,5 t 5500 lbs	5,25 t 11550 lbs	3,75 t 8250 lbs	2,5 t 5500 lbs					
VCGH-S 10 *	4 t 8800 lbs	8 t 17600 lbs	5,6 t 12300 lbs	4 t 8800 lbs	4 t 8800 lbs	8,4 t 18500 lbs	6 t 13200 lbs	4 t 8800 lbs					
VCGH-S 13 *	6,5 t 14300 lbs	13 t 28600 lbs	9,1 t 20000 lbs	6,5 t 14300 lbs	6,5 t 14300 lbs	13,65 t 30000 lbs	9,75 t 21450 lbs	6,5 t 14300 lbs					
VCGH-S 16	10 t 22000 lbs	20 t 44000 lbs	14 t 30800 lbs	10 t 22000 lbs	10 t 22000 lbs	21 t 46200 lbs	15 t 33000 lbs	10 t 22000 lbs					
VCGH-S 20	16 t 35200 lbs	32 t 70400 lbs	22,4 t 49300 lbs	16 t 35200 lbs	16 t 35200 lbs	33,6 t 74000 lbs	24 t 52800 lbs	16 t 35200 lbs					
VCGH-S 22	20 t 44000 lbs	40 t 88000 lbs	28 t 61600 lbs	20 t 44000 lbs	20 t 44000 lbs	42 t 92400 lbs	30 t 66000 lbs	20 t 44000 lbs					

Table 1

* are replaced by type VABH-W

The welding should only be carried out according to EN 287 or AWS Standards by an authorized welder.

Welding sequence:

- Tack Weld at the right position. Before carrying out the top run, carefully clean the root.
- The welding process must not be interrupted for such a time that the welding plate loses the welding temperature
- The fillet welding process had to be carried out circulated

Welding beam

	size	length	volume
VCGH-S 6	a = 5	247 mm	ca. 8,3 cm ³
VCGH-S 8	a = 5	352 mm	ca. 10,6 cm ³
VCGH-S 10	a = 6	410 mm	ca. 17,5 cm ³
VCGH-S 13	a = 8	490 mm	ca. 36,7 cm ³
VCGH-S 16	a = 8	580 mm	ca. 42,5 cm ³
VCGH-S 20	a = 8	750 mm	ca. 52 cm ³
VCGH-S 22	a = 8	770 mm	ca. 56 cm ³

Tabelle 3

Welding procedure + Welding filler metals :

	Europe (BRD, GB, F ..)	USA, Canada, ..
	Mild steel, Low alloyed steel,	
GAS SHIELDED WIRE WELDING	EN 440 G4Si1 z.B. Castolin 45250	AWS : A 5.18 ER 70 S-6 z.B. Eutectic MIG-Tec Tic A88
Stick Electrode Direct Current	EN 499 E 426 B32 H5 z.B. Castolin 6666 * 6666 N*	AWS : A 5.5 E 8018-G E 7016 z.B. Eutectic 6666/35066 CP*
Stick Electrode Alternating Current	EN 499 E 380 RR 12 z.B. Castolin 35086 CP 6600	AWS : A 5.1 E 6013 z.B. Eutectic Beauty Weld II
TIG Tungsten Arc Welding	DIN 8575 WSG CrMo1 z.B. Castolin 45252 W	AWS : A 5.18 ER 70 S-6 z.B. Eutectic TIG-Tec-Tic: A 88

Table 2 * Follow the drying instructions !

Welding seam definition:

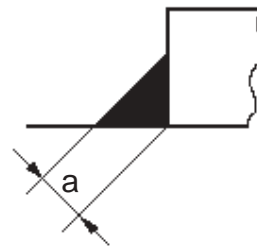

The specific processing informations of the welding fillers have to be attended.

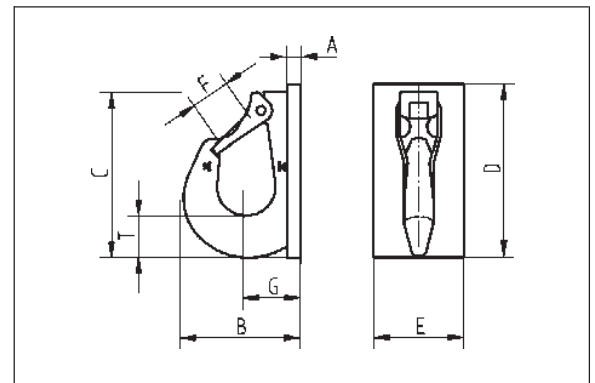

Type	WLL t	weight kg	A	B	C	D	E	F	G	Welding beam a	ref-no.	Safety set
VCGH-S 6 *	1,5	0,6	10	68	97	100	60	25	37	5	7984039*	7100299
VCGH-S 8 *	2,5	1,4	10	84	126	135	70	30	41	5	7984041*	7100300
VCGH-S 10 *	4	1,9	12	106	148	155	80	35	50	6	7984043*	7100301
VCGH-S 13 *	6,5	3,3	15	120	170	185	90	40	60	8	7984045*	7100302
VCGH-S 16	10	5,0	15	141	200	220	100	48	70	8	7984047	7100303
VCGH-S 20	16	8,4	20	187	272	288	120	63	87	8	7984310	7101604
VCGH-S 22	20	15,4	20	196	276	292	120	63	92	8	7984312	7101604

Table 4

* are replaced by type VABH-W